

Plan View

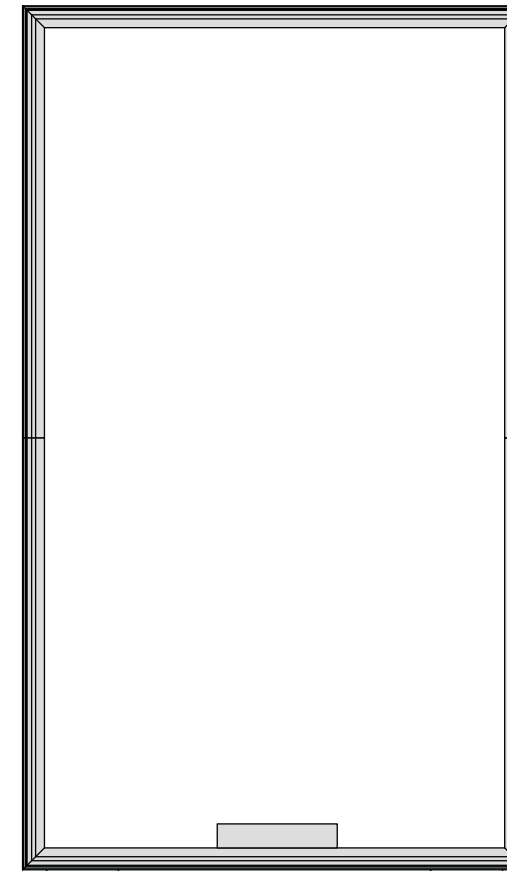

Front View

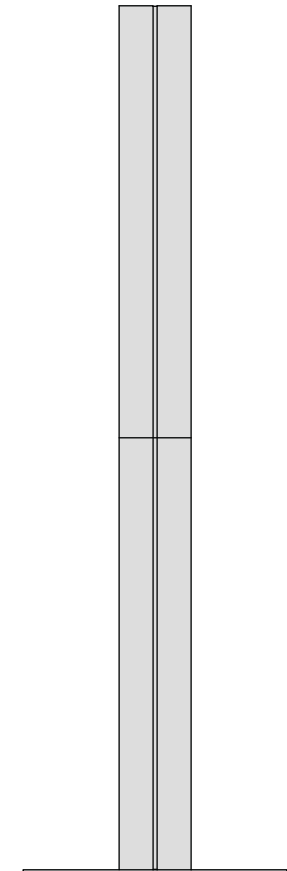

Side View

SETUP INSTRUCTIONS

General Setup Instructions

- Read entire setup instruction manual prior to unpacking parts and pieces.
- The setup instructions are created specifically for this configuration.
- Setup instructions are laid out sequentially in steps, including exploded views with detailed explanation for assembly.

Cleaning & Packing

- For Cleaning Metal, Plex, & Laminate Parts: Use a **MILD NON-ABRASIVE** cleanser and soft cloth/paper towel to clean all surfaces.
- Keep exhibit components away from heat and prolonged sun exposure.
- **Heat and UV exposure will warp and fade components.**
- Retain all provided Packing Materials. All provided packing materials are for ease of repacking & component protection.

Disassembly

- For loss prevention, tighten all set screws and locks during disassembly.

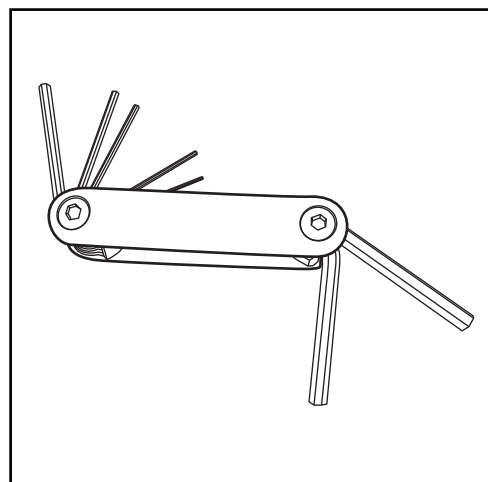

Hex Tool - Essential for Assembly

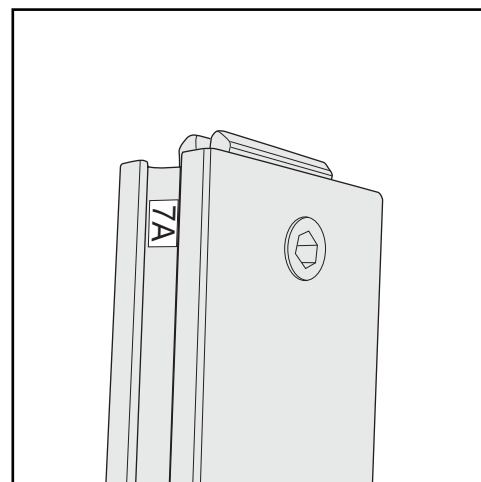

Part Identification - Numbering

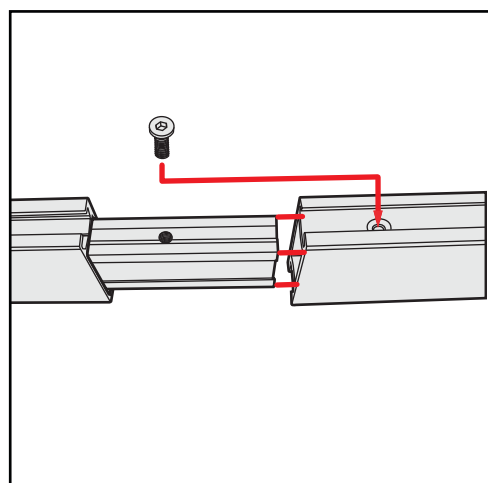

Spline Connection

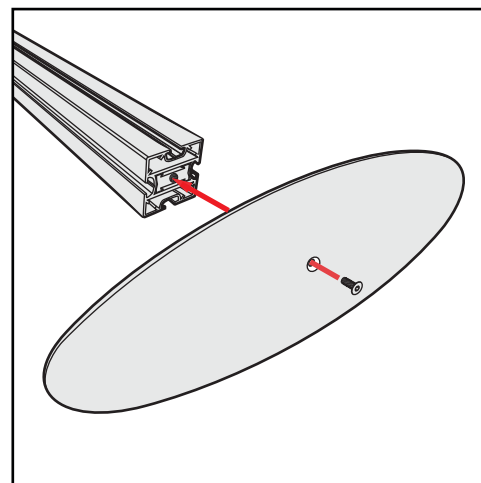

Base Plate & Extrusion Connection

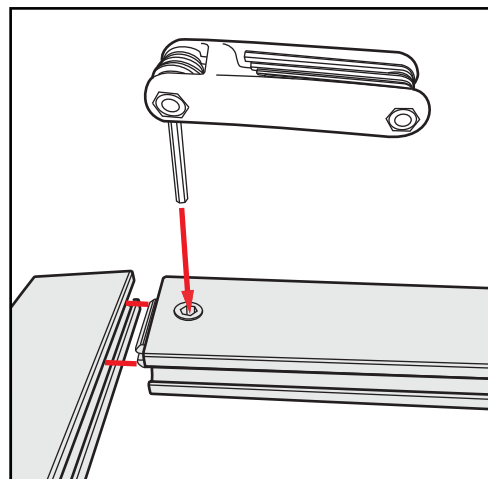

Extrusion & Lock Connection

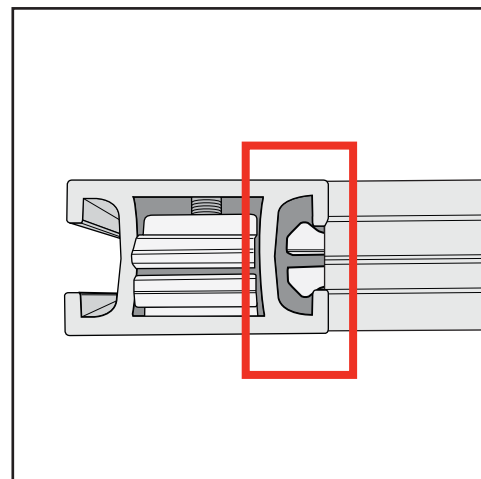

Engaged Lock



WARNING

DO NOT USE POWER TOOLS



LADDERS OR LIFTS
MAY BE REQUIRED

ALL CONNECTIONS MUST
BE TIGHTLY SECURED



Straight Connection

When assembling frame, first attach all **straight connectors**, then attach **corner connectors**.

- 1) Place extrusions end-to-end.
- 2) Loosen all knobs, then slide **straight connectors** across the seam of extrusions.
- 3) Tighten all knobs to secure connection.

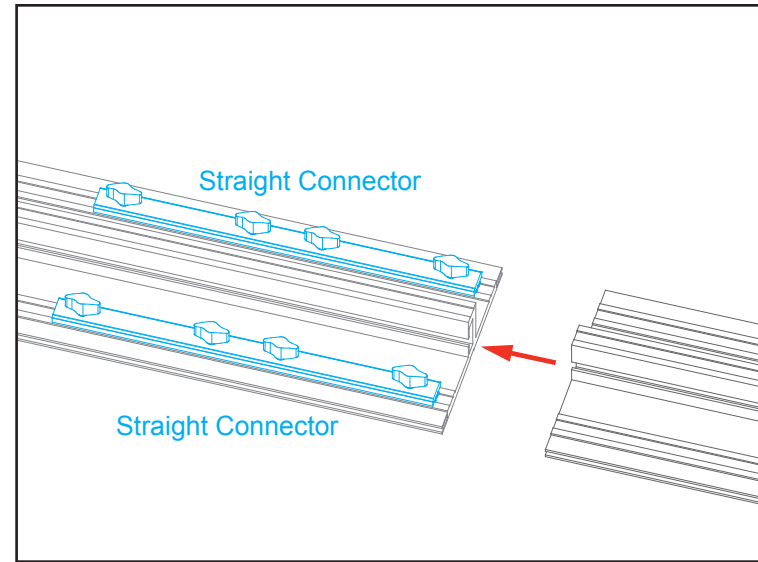

Slide both connectors across seam of extrusions. Tighten all knobs.

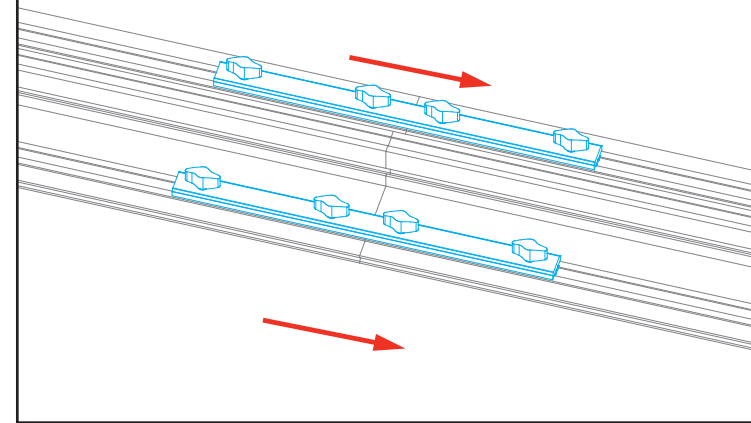

All knobs must be tightened securely to ensure a proper connection.

Disassembly

- 1) Loosen all knobs.
- 2) Slide connectors off of one extrusion.
- 3) Tighten knobs to prevent loss during packing & shipping.

Keep straight connectors in groove of extrusion. Do not remove connectors during disassembly.

Corner Connection

- 1) Loosen knobs, then slide vertical extrusions onto **corner connectors** of **lower** horizontal extrusion.
- 2) Slide **corner connectors** of **upper** horizontal extrusion into grooves of vertical extrusions.
- 3) Tighten all knobs to secure connection.

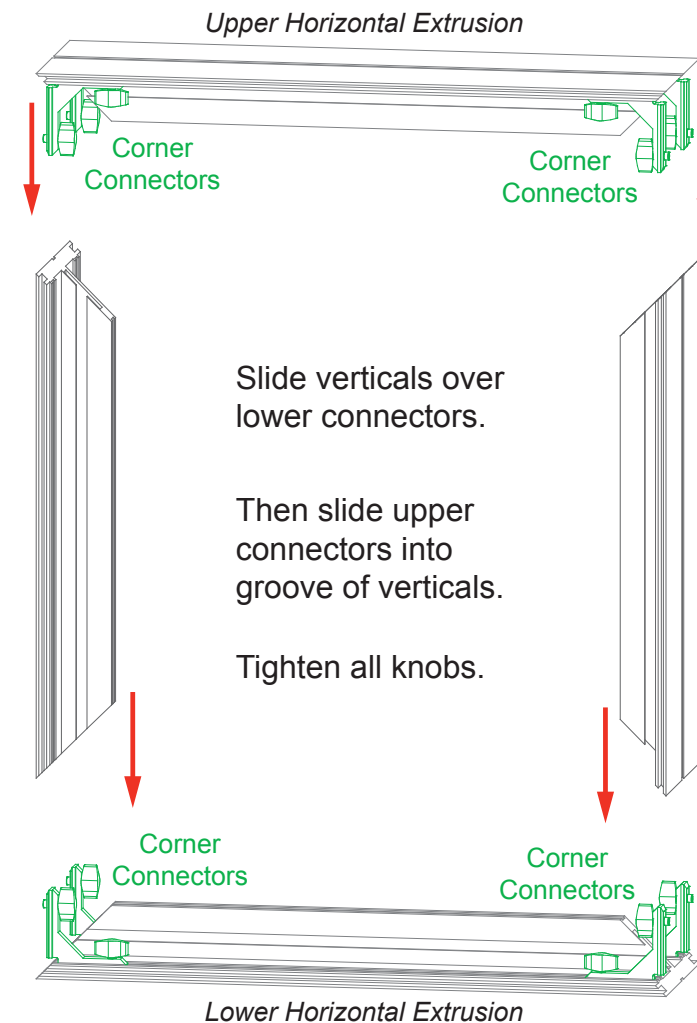

Slide verticals over lower connectors.

Then slide upper connectors into groove of verticals.

Tighten all knobs.

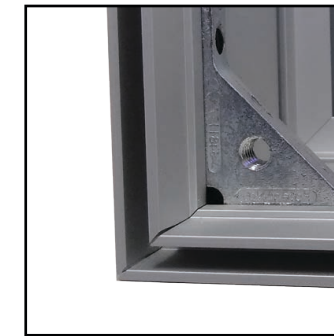

Adjust connectors if necessary to prevent gaps in connection.

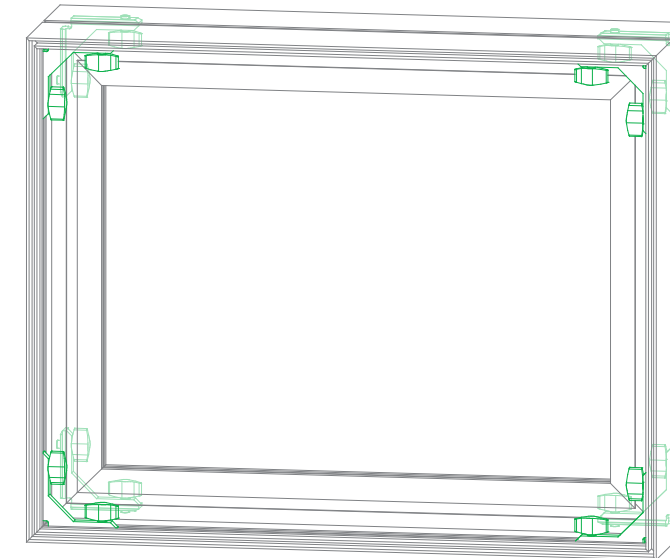

COMPLETED ASSEMBLY

All knobs must be tightened securely to ensure a proper connection.

Disassembly

- 1) Loosen knobs on vertical extrusions.
- 2) Slide the vertical extrusions off of **corner connectors** on lower and upper horizontal extrusions.

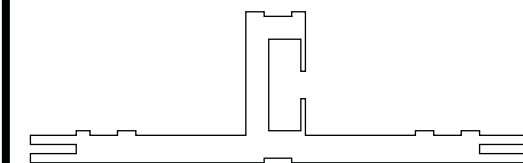

CEI152 Profile

SEG Graphic Installation *in 3 Steps*

STEP 1: Attach Corners

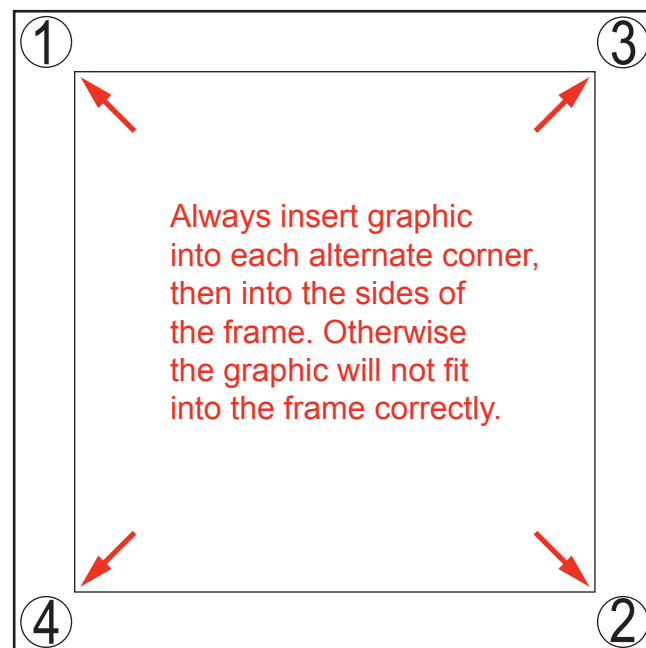

STEP 2: Attach Middle

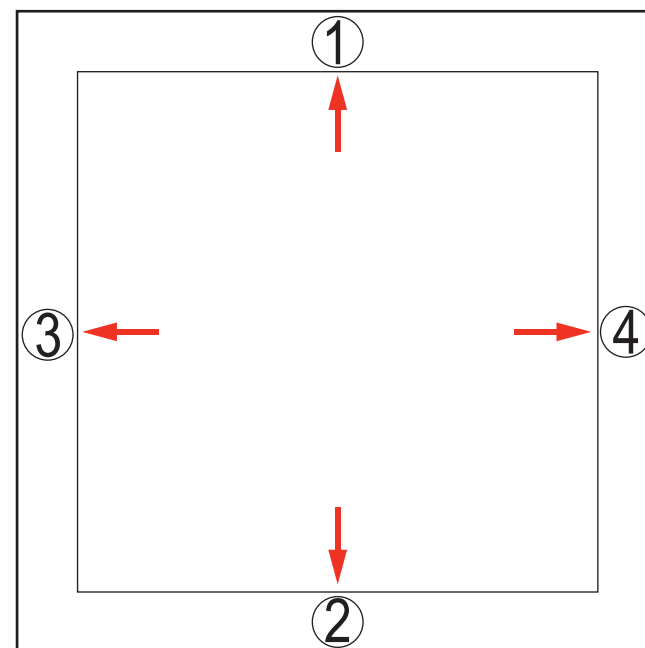

STEP 3: Attach Sides

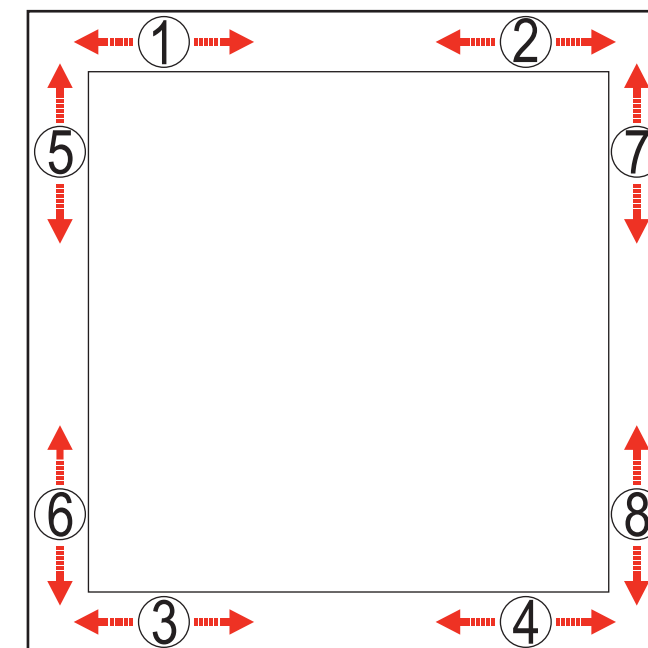

Insert narrow side of silicone welt into the channel at corner 1, with fabric to the outside.

Repeat for opposite corner 2, then corner 3, then corner 4.

Once corners are attached, press the middle of edge 1 into the channel. Then press middle of edge 2 into the channel on opposite side.

Repeat with edge 3 & 4.

Once the middle of sides are attached, fully press the silicone welt into the channel, between center and corner at location 1. Repeat the process between center and corner at location 2.

Do the same for welt on opposite side, at locations 3 & 4. Then repeat for locations 5 & 6 and 7 & 8.

Once the welt is fully inserted on all sides, smooth out edges as needed for a perfect fit.

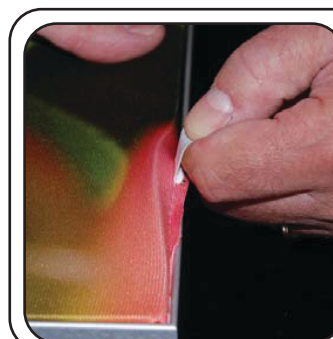

To remove the graphic from the frame, locate the fabric **pull tab**. Gently pull on the tab to remove the graphic.

Install video:



Top View of Each Level

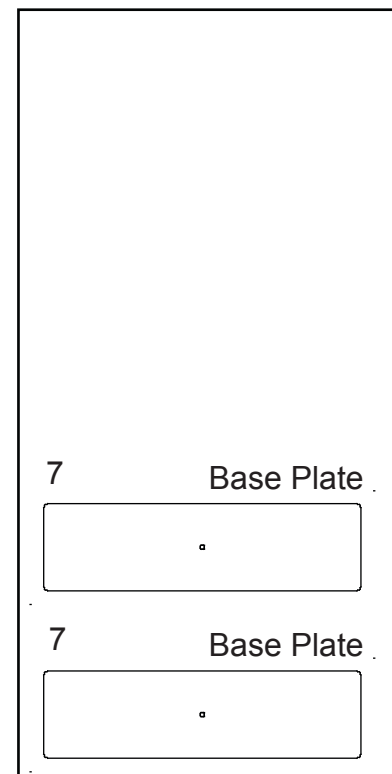

Level 1
(Bottom level)

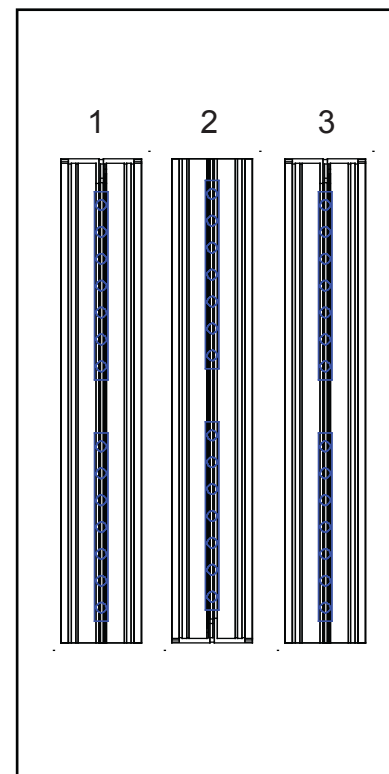

Level 2

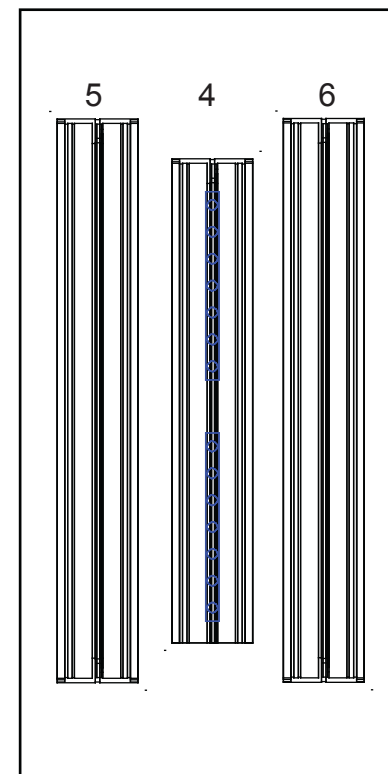

Level 3

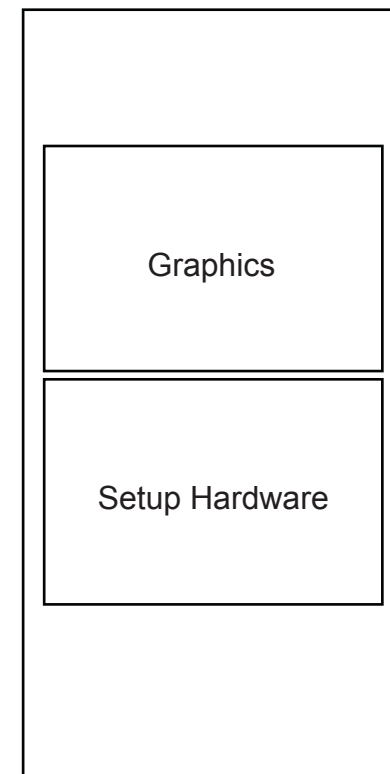

Level 4

Item	Qty.	Description
1/2	1/1	36"h CEI152 Vertical Extrusion with 1 miter
3/4	1/1	36"h CEI152 Vertical Extrusion with 1 miter
5,6	1,1	42"w CEI152 Horizontal Extrusion with 2 miters
7	2	6" x 22" Rectangular Base Plates
-	1	U-Channel

Steps:

- 1) Attach u-channel to horizontal [5]. See [U-Channel Connection](#) detail.
- 2) Assemble verticals [1-2] & [3-4] together. See CEI152 Frame Assembly sheet for instruction. See also [CEI152 Straight Connection](#) detail.
- 3) Connect horizontals [5,6] between vertical assemblies [1/2] & [3/4]. See CEI152 Frame Assembly sheet for instruction. See also [CEI152 Corner Connection](#) detail.
- 4) Attach Base Plates [7] to horizontal [5], using bolts, washers, and wing nuts then lift assembled frame upright.

Assemble frame flat on floor.

*** U-Channel Attachment**

Slide V4 connectors into top groove of horizontal extrusion. Tighten set-screws to secure. Attach U-Channel to connectors, using bolts.

Note: V4 connectors stay attached when packing.

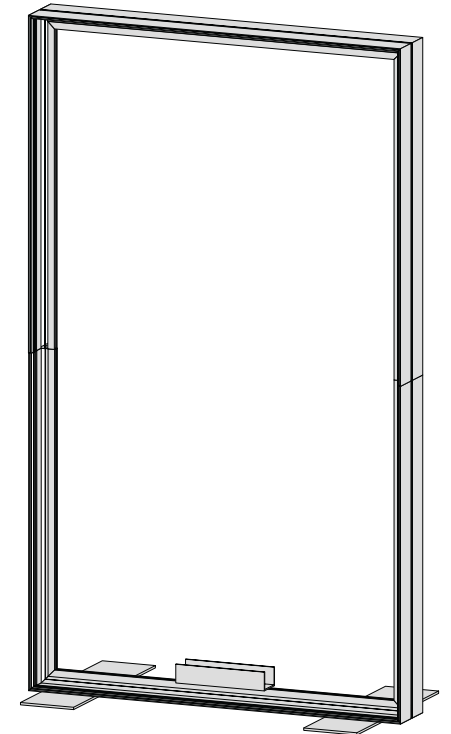
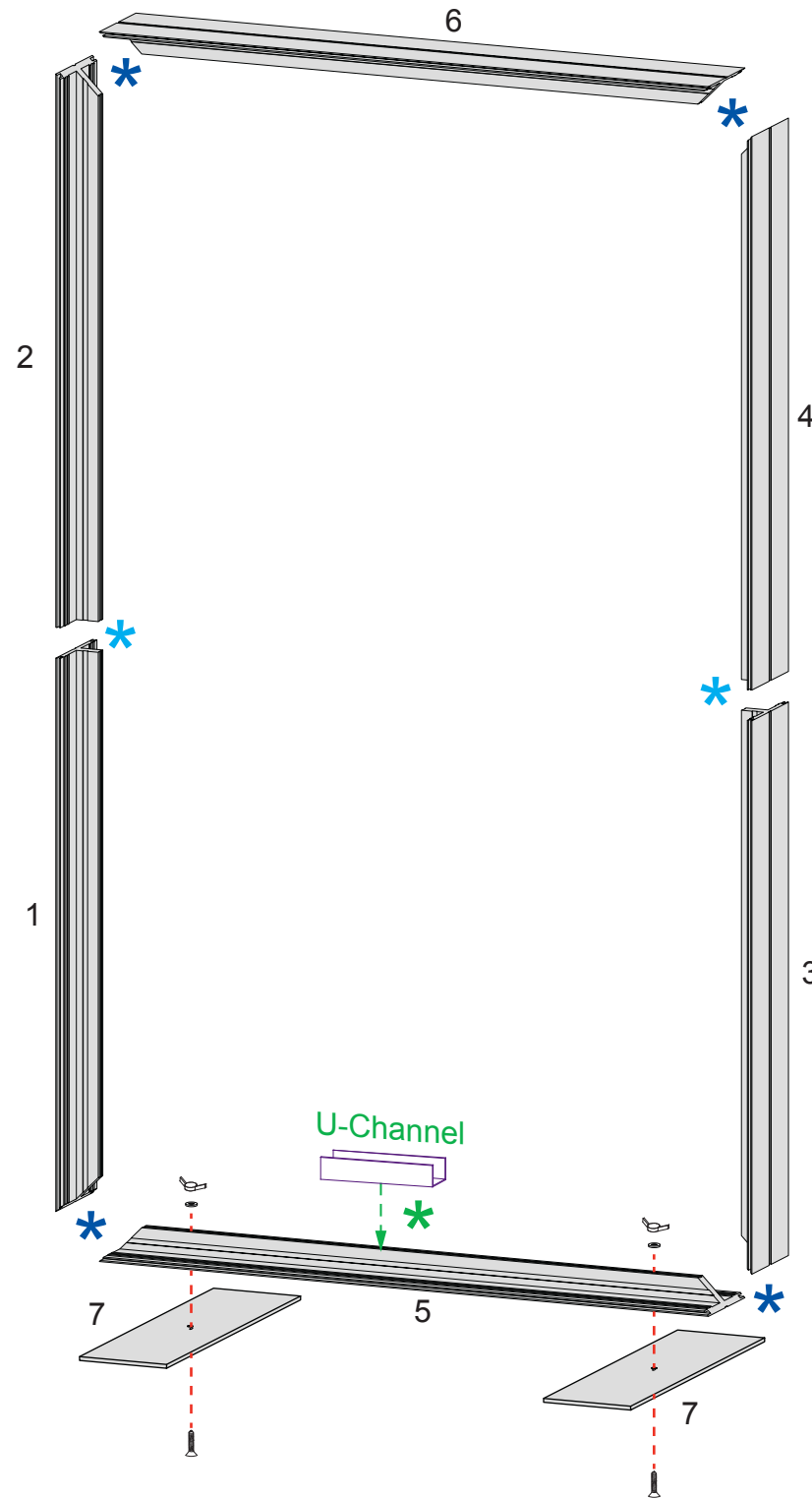

When assembled

*** CEI-152 Straight Connection**

1. Place extrusions end-to-end.
2. Slide connectors across seam of extrusions.
3. Tighten all knobs to secure connection.

*** CEI152 Corner Connection**

1. Slide extrusion onto corner connectors.
2. Tighten all knobs to secure connection.

Steps:

- 1) Connect lighting cords between lights and attach transformer. See [Light to Light Connection](#) & [Light to Transformer Connection](#) details.
- 2) Then set transformer into u-channel. See [U-Channel Attachment](#).
- 3) Run main power cord through wire management hole out bottom of frame.

- 4) Install SEG graphics to front and back of assembled frame. See [SEG Graphic Installation in 3-Steps, The Perfect Fit](#) page.

